

Orange County Model A Ford Club

THE DISTRIBUTOR

60 Years



Volume 62 Issue 5

May, 2022

Editor Tissy Smith-Hatcher

Life doesn't come with a manual, it comes with a mother.
Happy Mother's Day

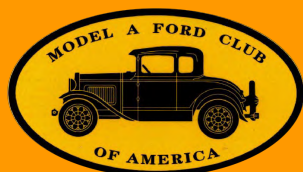

Inside this issue:

President's Message	2
Board Member Contact Info/General Meeting Minutes	3
Calendar/Swap Meets	4
Mitchell Overdrive Installation	5
Jim's Tech Tip	6
Sunshine & Sorrow	7
Mt. Baldy Tour	10
Highlights of the March Tech Seminar	12
Los Angeles County Fire Museum Tour	13



MAY 21ST (SATURDAY)
8:30AM COFFEE & DONUTS
9:00AM SEMINAR BEGINS

TOPIC: REPAIRING YOUR BRAKES



DON DORMEYER'S HOUSE
2229 E MEATS AVE
ORANGE

THIS WILL BE A PARTICIPATORY SEMINAR AND YOU MAY WIN A DOOR PRIZE!

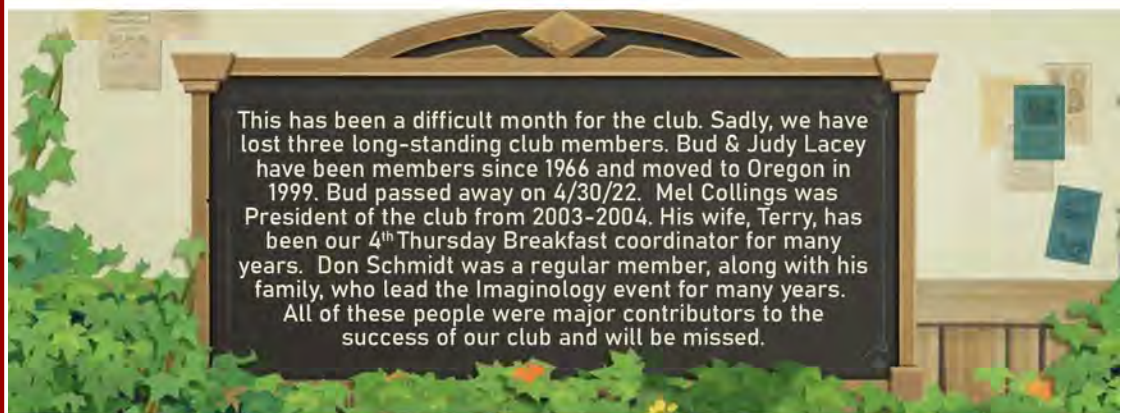

This has been a difficult month for the club. Sadly, we have lost three long-standing club members. Bud & Judy Lacey have been members since 1966 and moved to Oregon in 1999. Bud passed away on 4/30/22. Mel Collings was President of the club from 2003-2004. His wife, Terry, has been our 4th Thursday Breakfast coordinator for many years. Don Schmidt was a regular member, along with his family, who lead the Imaginology event for many years. All of these people were major contributors to the success of our club and will be missed.

JUST WHAT SHE NEEDED



Mary Dormeyer is trying to get back to being healthy. She seems to be just fine with one more Model A Ford in the yard. This one is clearly air conditioned.

Get ready.
They're coming . . .



(If you are unable to attend the general meeting, you will have an opportunity to pick up at various locations around Orange County during June. Locations to be identified in June's newsletter.)

News From the President

By Louise Hall

We certainly pulled off a successful Pancake breakfast in March. Congratulations to all who worked hard to make this event happen. We have had a debriefing meeting with the board and the team leaders. For the most part, everything went smoothly, with few issues. We spent some time discussing the location and the parking. A committee will be meeting with the City of Orange leadership to make some suggestions for next year. We are still considering other location options. However, Hart Park meets our needs very well with few exceptions.

In April a few of us drove to Paso Robles to attend the CCRG (Central California Regional Group) event. It was a great overnight trip. The tours offered were interesting and the option we chose turned out to be through some beautiful rolling hills and farmlands. I wish you had been able to join us. If tri-tip is of any interest to you, this is what this part of California is famous for. Next year they will be meeting in Santa Maria, which is a little closer. As soon as we get a date, put it on your calendar!

May is known for its lovely weather and beautiful spring flowers. I wish I could say that April showers bring May flowers, but the drought continues. May is also the month that we celebrate and remember those who have served in our armed forces on Memorial Day. This year, Fairhaven Memorial Park in Santa Ana will continue with their traditional celebration. They have asked us to provide cars once again at the entrance to their memorial park.

If you haven't attended this even before, I highly recommend it. We will arrive early, about 8:00 am on May 30, to line up our cars at the entrance. Donuts and coffee will be available. We then move over to the program area to set up our chairs to watch a very nicely done patriotic program. The Park will provide hot dogs, chips and drinks. (Have you ever had hot dogs for breakfast?) I hope you will join us.

And on a personal note, in May Rick and I will be in Northern California to visit some friends on our club's meeting day. And in June, we will be on a cruise with our family to celebrate our 50th anniversary (which was 2 years ago!) on meeting day. Life just happens this way sometimes. Eric Engle, Vice President, will be presiding at the Board meetings and General meetings. He will also keep you updated with upcoming events. Lots to talk about!

Keep those cars on the road! I'll see you at an event and at the meeting in July!

Louise



DON SCHMIDT



Don Schmidt, long-time member, passed away on April 29, 2022. Don and Colleen have been active club members since 1996. We offer our support to Colleen and their family during this difficult time.

He can only be physically gone but never the life lived and the memories shared. Have faith, be strong and know you are not alone.

2022 BOARD MEMBERS

President – Louise Hall
714-282-0499/rickandlouise76@gmail.com
VP/Activities – Eric Engle
714-552-2630/eengle@socal.rr.com
Secretary – Don Dormeyer
714-342-3259/don@dondormeyer.com
Treasurer – Darwin Kibby
310-938-6872/dkibby714@att.net
Technical – Michael Edmonson / 714-615-5751/michael.edmonson@me.com
Editor – Tissy Smith-Hatcher / 714-546-8554/tissysmith1@gmail.com
Immediate Past President – Jim Runyon
714-527-1829/jamesrunyon@aol.com

COMMITTEES

ACCC Representative – David Knapp
Breakfast Committee – Terry Collings
Club Greeter – Linda Tom
Election Chairperson – TBD
Historian & Librarian – Bruce MacIntosh
Merchandise Director – Perry Wilson
Pancake Breakfast Setup & Coordination – Frank Reese, Don Ratzlaff and Richard Bolls
Raffle – Ed Cote
Refreshments –
Regional Representative, SCRG - Carolyn Ratzlaff
Sunshine & Sorrow – Marilyn Hawkins
Webmaster – Bruce MacIntosh

We have removed all Committee members' emails and phone numbers in order to ensure their privacy. Members can find this info in your roster.

Please Note: Some information contained in our newsletter has been reprinted from other newsletters; we thank and acknowledge them.

Orange County Model A Ford Club General Meeting Minutes on April 11, 2022 Meeting held at First Christian Church in Orange, CA

Members in attendance: 46

President Louise Hall called the meeting to order at 7:45pm.

Member Diane Gaughen led **the flag salute.**

Greeter Linda Tom introduced Phil Verzani, (looking for a Model A Tudor or coupe) and Brian Huffman who has purchased Glenn Johnson's 29' coupe.

Minutes: Sheila Plotkin moved and Pam Heiland seconded adoption of the minutes as printed in The Distributor. Motion approved.

Financial report: Darwin Kibby reviewed the details of the pancake breakfast and overall financial records. previously approved at the BOD meeting. No questions were elicited and records available for review.

Membership currently is 136.

Activities: Eric Engle reviewed potential tour to LA County Fire Museum for May, date to be determined. Meet up for Mt Baldy next week announced. Pam Heiland announced the annual veteran's celebration lunch and car show at Wilshire Ave. Community Church June 30, flyers available next month.

Technical: Mike Edmonson absent. Eric reported that the Saturday tech. seminar was well attended. Thanks to Richard Parrish for his yard, garage and lift.

Newsletter/Editor: Tissy Hatcher reported rosters would be available at May meeting. Photos and articles are always welcome and encouraged by deadline of 25th of each month.

Sunshine & Sorrow: Marilyn Hawkins reported that her own spouse Bob is currently in a rehab. facility following hospitalizations.

Kaci Terens and Lori Goff thanked everyone for attending the memorial for grandpa and dad Joe. He will be missed by us all.

Merchandise: The Wilsons are absent this month.

Refreshment Organizer: Jim Runyon thanked Linda Tom, Ratzlaffs and McCalls for this month's treats. See Jim to sign up for future meeting.

Radiator Badges” Becky MacIntosh reports production still pending.

Raffle ticket drawing: Kathy Glendinning held the right number.

Roster drawing: Perry Wilson was not present to receive the \$70.00.

Hard Luck Trophy Candidates: Norm Kredit, the current holder of the trophy is taking it home again with his sad report about breaking down at a major intersection on his way to the Saturday seminar. Don Ratzlaff and David Knapp immediately came to his rescue and got him to the seminar where it was determined that the starter had 'frozen'.

Norm was competing with Kaci Terens and family dealing with Joe's Model A at his memorial service when the car wouldn't start and had to be pushed with Kaci steering. What a sight! Kudos to both drivers for their positive attitudes and persistence.

Other Announcements: Ron Andrews has a contact for powder coating.

Pancake Breakfast. A lively discussion was held to review pros and cons of the well-attended and successful event including huge thanks to everyone who helped out, especially Frank Reese and Richard Bolls; Becky (cont'd on Page 8)



Upcoming Tours and Activities Calendar



May 7 (Sat) First Saturday Breakfast BS Session ~ Coco's Restaurant & Bakery, 12032 Harbor Blvd, Garden Grove 92840

(cross street is Chapman) 8am

May 7 (Sat) City of Orange Parade, participating through Old Towne Preservation Assn, 10am (check in 9:45am). Contact Bruce MacIntosh to participate at brucem@genimage.com (see page 8 for more info)



May 12 (Thu) General Meeting will be at 7:30pm at First Christian Church of Orange, 1130 E Walnut, Orange (between

Tustin & Cambridge). Follow the signs. Lots of free parking. The Board Meeting will be held at 6:30pm and all are welcome.



May 14 (Sat) Happy Days Drive By at Laguna Woods Village, meeting at 8:45am-9:45am parking lot of Lutheran Church of the Cross, 24231 El Toro Rd, Laguna Woods (see details on page 11)



May 19 (Thu) Los Angeles County Fire Museum tour, meeting at Starbucks, 2219 W Ball Rd, Ana-

heim (cross street Brookhurst) at 8:45-9:15 (additional details on Page 13)



May 21 (Sat) Technical Seminar on Brakes at Don Dormeyer's home, 2229 Meats Ave, Orange, 8:30am

for coffee and donuts, 9am seminar begins. This is a participatory seminar and will include a door prize



May 26 (Thu) Fourth Thursday Breakfast location to be determined at 8:30am. For more

info, contact Kathie McCall or Terry Collings

May 30 (Mon) Memorial Celebration at Fairhaven Memorial Park, 1702 Fairhaven Ave, Santa Ana. Begin to line up at 8am. More details to follow



Jun 4 (Sat) First Saturday Breakfast BS Session ~ location to be determined

Jun 4 & 5 (Sat/Sun) Huntington Beach Rod & Custom Show, our cars will be on 6/4 and on 6/5 are high and luxury cars and motorcycles at Huntington Beach Central Park at Goldenwest and Talbert from 9am-2pm. Car entrance fee \$40; general admission \$10



Jun 9 (Thu) General Meeting will be at 7:30pm at First Christian Church of Orange, 1130 E

Walnut, Orange (between Tustin & Cambridge). Follow the signs. Lots of free parking. The Board Meeting will be held at 6:30pm and all are welcome.

Jun 12-17 MAFCA National Convention, Kerrville, TX (note date change) hosted by Alamo A's. Contact Jimmy Taylor 830-660-8094



Jun 23 (Thu) Fourth Thursday Breakfast location to be determined at 8:30am. For

Swap Meets/Car Shows

May 7 (Sat) 2nd Annual Shifting Gears Rally at San Diego Museum, 6:30am

May 8 (Sun) Long Beach Hi Performance Show and Swap Meet, Long Beach Veteran's Stadium, 5000 Lew Davis, Long Beach 90808, 6am-1pm

May 22 (Sun) Antique Nationals Drag Race & Car Show, 50th Celebration at Irwindale Speedway, Adults \$25

Jun 3—Sep 30 (Fridays) Cruise the Beach, Redondo Beach Marina 3pm-7pm

Jun 5 (Sun) Long Beach Hi Performance Show and Swap Meet, Long Beach Veteran's Stadium, 5000 Lew Davis, Long Beach 90808, 6am-1pm

Jun 12 (Sun) Pomona Swap Meet & Classic Car Show, Fairplex, 1101 W McKinley Ave, Pomona 5am-2pm

Jun 17 -18 Pomona Swap Meet & Classic Car Show, Fairplex, 1101 W McKinley Ave, Pomona 5am-2pm

Jun 18 (Sat) Whittier Area Classic Car Show, 8100 Colima Rd, Whittier, 9am-3pm



On April 30, 2022 Steve Pavich and Michael Edmonson drove their Model A's to Tom Endy's home for Mitchell Overdrive installations. It took seven hours to install both Model A's with the overdrives. Several current and former OCMAFC members showed up to assist including Tom Endy, Steve Pavich, Michael Edmonson, Eric Engle, Red Sickman, Richard Parrish and others. Tom Endy has an expert crew to perform the technical and physical work to be done. A donation of \$500 is requested and is sent to student automotive programs in the area.

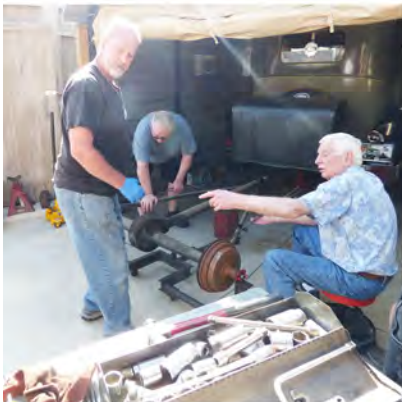

Both Michael Edmonson and Steve Pavich were very pleased with their Model A's performance. Steve remarked: "my car went from 45mph to 60+ top speed on the freeway!" "Let's go touring !"



Article & Photos Courtesy of Steve Pavich

Jim's Tech Tips ~ "Grease Fitting Added to 7-tooth Steering Gear"

The Ford Service Bulletin from September, 1928, has a brief mention of adding

FORD SERVICE BULLETIN for September

PAGE 281

NEW LUBRICATOR FITTING IN STEERING GEAR HOUSING

The drilled hole in the steering sector shaft, through which the lubricant in the steering gear housing was carried to the sector shaft bushings, has been discontinued. Sector shaft bushings are now lubricated by means of a lubricator fitting placed in the steering gear housing. (See A, Fig. 570.) Lubricant should be forced into this fitting every 2,000 miles.

Should an instance arise where it is necessary to install the present design sector in an old steering gear assembly, it will be necessary to install a lubricator fitting in the housing. This is done by drilling a $21/64$ " hole $2-3/32$ " back from center line of flange where housing is bolted to frame. (See Fig. 571.) The hole should be drilled through housing and sector bushing and then tapped with a standard $1/8$ " pipe tap. When tapping the hole, do not tap too deep. The hole should be tapped just deep enough so that when the lubricator fitting is screwed down tightly approximately two threads on the fitting will remain above the surface of the housing. (See Fig. 571.)

You fill the steering gear box with the very heavy and thick 600W oil, and you squirt a little grease into this fitting that you are adding. The grease will lubricate the sector shaft, and it will form a little bit of a barrier that will slow down (not stop) the 600W gearoil from seeping out the sector shaft.

Have a Model A Day!

Jim

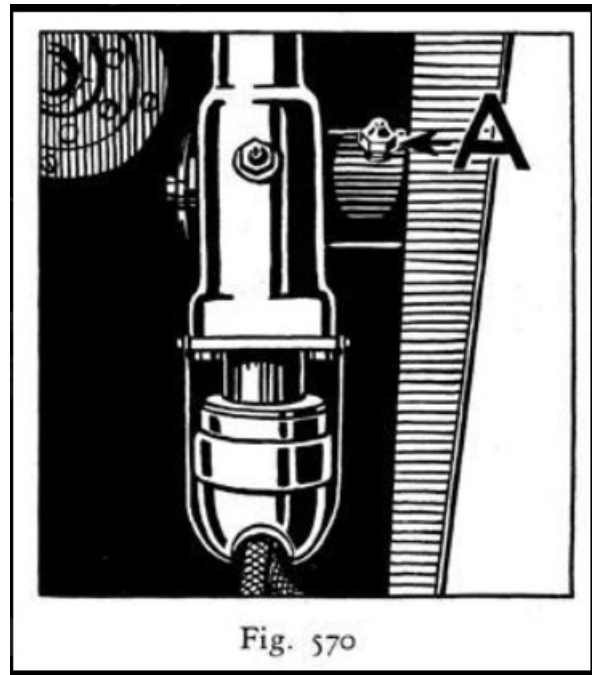

Fig. 570

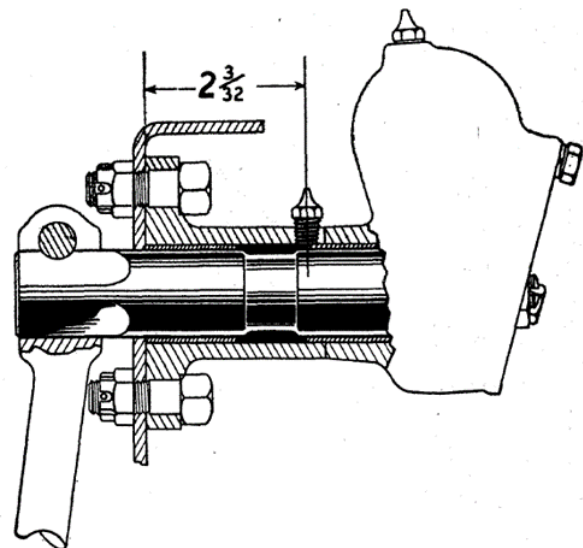

Fig. 571

Sunshine & Sorrow

By Marilyn Hawkins
m_hawkins33@cox.net

Sunshine: Joined the group that toured Mt. Baldy in April. Beautiful day w/lunch at the Mt. Baldy lodge. I'd forgotten the many, I repeat many, switchback turns on our way up the mountain. *Sorrow:* **Mary Dormeyer** underwent surgery on April 21 for removal of her appendix. Hopefully, the recovery will be short due to key-hole surgery (laparoscopy) through a couple incisions. In the last 30 days, **Bob Hawkins** has been in the Hospital—Rehab—Hospital—Rehab. He came home on April 28 w/oxygen equipment. **Kay Nettles** had surgery for insertion of a heart monitor needed for irregular heartbeat. **Bruce Harris** underwent brain surgery due to a fall early April. He was in ICU until the drainage tubes and staples were removed. Still in the hospital when a bout of seizures occurred...back to ICU late April. Now in physical therapy. We lost **Mel Collings, Bud Lacey and Don Schmidt** this month. Our hearts and prayers go out to their wives and families.

As our bodies continue to age, we all need to exercise, like simply walking 20-30 minutes a day. Stay healthy!



Friends fill our lives with love and laughter



**OCMAFC Supports
 Orange County
 Ronald
 McDonald
 House**

Now that the Pancake Breakfast is behind us, it is time to give some attention to one of our charities, the Orange County Ronald McDonald House. Did you know that 92.5% of the money donated to the Ronald McDonald House goes directly to the program? Items they are needing are toiletries such as hand and body lotion, hair ties and headbands, lip balm, deodorant (men's and women's), soap, tooth paste, tooth brushes, socks, shampoo, hair brushes and combs. They provide Welcome Bags that might also include water bottles, children's coloring books, activity books, and crossword/Sudoku books for the parents. You can help support families by bringing these items to a club meeting. Due to the sensitivity of the patients and families, please donate new items only. Kathie McCall will collect and deliver the items to the Ronald McDonald House.
 Thank you for your donations.



No grief is greater
 than the departure
 of such a kind man
 as him. May his soul
 Rest in Peace.

Mel Collings
 1932-2022

The first parade was held in 1933, so this truly is a historic event. Originally, the parade marked the beginning of the Valencia orange packing season. The OCMAFC will have 5 members cars in the parade this year, representing the Old Towne Preservation Association. The parade starts at 10am with a short march down Chapman Avenue. There will also be cars from the Orange County Model T Ford Club. So come out and enjoy this nostalgic event amid the ambiance of old town Orange.

Bruce MacIntosh
(949) 857-4723



(cont'd from Page 3) and Bruce MacIntosh for the food purchases and maintenance of the storage unit, Karen Gaynor and Sheila Plotkin for handling the raffle, Don Ratzlaff and Jim for picking up and driving the delivery truck, then unloading and returning it and all the individuals who assisted with that time consuming detail. Ron Andrews headed up parking detail for the first time and thanked the crew who helped. All of the members, volunteers, and especially Jeremy Gaynor who came from New York to be the announcer were applauded for their willingness to make this post Covid Pancake Breakfast a fun and successful event.

There will be a post breakfast wrap up on April 19 @ 1:30 pm.

Louise announced she and Rick will be out of town for the May and June meetings and VP Eric Engle will preside. Minutes submitted by Kathie McCall for Don & Mary Dormeyer.

MECHANIC'S PRAYER

Our skills. Who art in fixing.
 Hallowed be thy hands.
 Thy cars will come.
 Thy will be done
 changing oil as it is
 replacing brakes.
 Give us this day with our
 new tools, and forgive
 the price of them.
 As we forgive those who lack
 car knowledge. Lead us not into many scars.
 But deliver us from stripped bolts.



∞ Amen ∞

**June 12-17
2022**

No Place Offers The Model A Experience Like The Texas Hill Country

MAFCA NATIONAL CONVENTION
 YO RANCH RESORT • KERRVILLE, TEXAS

From its spectacular scenery to its beautiful two-lane country roads, here you will experience our hobby the way it is meant to be at the 31st National MAFCA Convention!

FIND CONVENTION INFORMATION ONLINE AT: www.mafca.com

Some of the week's highlights:

- San Antonio's Famous River Walk
- The Alamo - Birthplace of Texas
- Great Sightseeing & Restaurants!
- Fine Point Vehicle Judging
- Era Fashions & Judging
- Restorers Class

Hosted by **ALAMO AS**

Deadline for submissions for the next Distributor is **May 20, 2022**
 Submit all Articles and ads to tissysmith1@gmail.com or mail to
 P.O. Box 10595
 Santa Ana, CA 92711

Don't Forget
 Renew your 2022 membership today
 Call 866-379-3619 or visit www.mafca.com

UPCOMING EVENTS

SAVE THE DATES :
"THE NEW MODEL A DAYS" at the Gilmore Car Museum, September 16 & 17
HISTORIC HOME TOUR on October 8th and 9th at 10am. Our cars would be parked in driveways of the homes/businesses during tours. You don't have to stay with your car.
IRVINE REGIONAL PARK'S 125TH BIRTHDAY CELEBRATION, November 5 (Sat)
NATIONAL AWARD BANQUET, in December, Golden, CO

MODEL A Roster Raffle

CURRENT JACKPOT 80 DOLLARS

If the roster jackpot grows to \$100, and the name pulled is not at the meeting, a second name will be pulled; should it get to \$200, up to 4 names may be called each month until a winner is in attendance.

Mt. Baldy Tour

By Eric Engle
VP/Activities Director

Well, once again, our annual Mount Baldy Tour was a resounding success. A very nice size group of club members made the 40+ mile up to the Mount Baldy Lodge to have a wonderful lunch together. Thank you Don Ratzlaff once again for all your efforts in making it a great tour. Such a wonderful way to kick off the "Touring Season" for our club. And thanks to Leonard Driver and Don Dormeyer for the photos. Don D. sacrificed one of his cameras to get the one shot of the cars on the road. Hoping for a very artsy angle for a video, Don placed his camera in the road, hoping that everyone would straddle it. Well, you guessed it...someone missed...or should I say, "didn't miss"... Don now has a flat camera. Curses!!! Flat cameras aside, the tour was fantastic and the day was even better than that!! Thanks to everyone for joining in to make a great day touring.



Mt. Baldy Tour April 13, 2022



HUNTINGTON BEACH ROD & CUSTOM SHOW

Saturday, June 4, 2022

Exhibition: 9:00 AM - 2:00 PM
Awards Start: 2:00 PM

Huntington Beach Central Park
Goldenwest Street at Talbert Avenue

- Spectator Admission: \$10
- On Stage Entertainment
- Operating Model Trains: 9 AM - 2 PM
- Sports Center Parking: \$1 All Day
- Children under 16 Free with Adult
- Food Vendors



REGISTRATION FEES
RODS & CUSTOMS \$40
MOTORCYCLES \$25

Register at
HBCONCOURS.ORG

The BS Breakfast

Saturday, May 7th
Coco's Restaurant & Bakery
12032 Harbor Blvd
Garden Grove, CA 92840
(cross street is Chapman).



Please arrive by 8am to ensure
we may sit as a group.
RSVP to Don Ratzlaff.



When: May 14th (Sat)
Where: Lutheran Church
2423 I El Toro Rd
Laguna Woods
Time: 8:45AM-9:45AM
Tour begins: 10:00AM

The Early Ford V8 club has invited our members to join other clubs in a "Happy Days" drive-by at the Laguna Woods Village.

The meeting place will be in the parking lot of the Lutheran Church of the Cross, across the street from the Laguna Woods Village.

Call or email Eric Engle (714-552-2630 or eengle@socal.rr.com) to let him know who is going. We need a head count as soon as we can for the Laguna Woods Security detail.

These tours through the retirement communities have always been DEEPLY appreciated by the residence, so let's get our old gems out and put a LOT of smiles on the folks....

Always nice to brighten someone's day in a Model A.

Highlights of the March's Technical Seminar

By Mike Edmonson
Technical Director

While March would be a better month to get our Model A's "up to snuff" for general driving and touring purposes, we chose to delay this technical seminar until April so we could all focus on our wonderful pancake breakfast – again, a shout out to everyone that participated and helped us get THIS event back on the road again too!!!

Back to our wonderful Model A's.....on Saturday, 9 April we had a workshop focused on annual maintenance, preparation for tours and some items you might want to bring along with you on a tour or longer drive (keeping the upcoming Mt. Baldy Tour in mind). A big thanks, once again, to Richard Parrish and the use of his backyard, tools, and lift; the lift makes some of our annual maintenance so much easier. Annual maintenance discussed included such topics as oil changes, lubrication points, and changing of water or antifreeze/coolant. We had a healthy discussion on types of oil, which will of course go on forever (10/30, 10 40, 15/40 , 20/50, or just plain straight 30wt – and even preferred brands!). We also discussed types of antifreeze and how the more modern "extended life" antifreezes are not only inappropriate, but even harmful to the Model A radiator and cast iron engine. We should be looking for the good old-fashioned green antifreeze comprised of ethylene glycol and uses "inorganic acid technology" (IAT) that Prestone makes. We also discussed alternatives to antifreeze which will be the topic of a future article.

As for tours, items to bring along included proper fan belts (why does Don Ratzlaff come to mind?), an extra distributor that is timed to your car (or maybe even one that isn't – using the Nu-Rex timing wrench timing is now quick and simple), condensers – both original style and modern, tools such as a

wrench and socket set to match the various sizes on the car, inner tubes (and maybe checking to see how that spare is doing on your car – note to self, I discovered mine was completely flat!) and maybe even a jack and some blocks of wood should you need them to elevate your car to proper height. Just a few of the items that came to mind. And a checklist was also made available to ensure we didn't forget anything (these are still available in a pdf format – just ask and I will email them out to you) before pulling your Model A out of the garage.

Lastly, several members took advantage of Richard's lift to change oil, lube the various points, and other aspects of annual (or semi-monthly if you drive your car that much) maintenance. Darwin Kibby changed his oil and finished up a lube job that he started back at home. This was also a good opportunity to inspect all areas found under the car without rolling or crawling around on your back. For newer members we also discussed the braking system and other potential problem areas; Darwin's car made for a great guinea pig! Frank Mowrer also had his souped-up Tudor there to both change and spill his oil (shhhh, don't tell Richard).

Looking to next month, our next tech seminar will be on May 21st at Don Dormeyer's home. Topic will be another one of those annual maintenance items: Brakes. We will discuss the how-to's and have the space to adjust 3-4 sets of brakes at a time, so plan to bring your Model A to this seminar as we want to adjust as many brakes as we can. (And Eric Engle has a special tool available to those that participate!)





THE GUIDED TOUR INCLUDES THE MUSEUM AND THE SHOP WHERE THE WORKERS RESTORE THE EQUIPMENT.

PHONE, TEXT OR EMAIL ERIC TO CONFIRM TICKETS AT 714-552-2630 OR EENGLE@SOCAL.COM

MEETING AT STARBUCKS 2219 W BALL RD ANAHEIM (CROSS STREET IS BROOKHURST) BETWEEN 8:45AM-9:15AM



**ORANGE COUNTY
MODEL A FORD
CLUB**

OCMAFC
P.O. Box 10595
Santa Ana, CA 92711

E-mail: info@ocmafc.org

Next General Meeting

[Second Thursday of every month]

Next Meeting May 12, 2022

Time: 7:30pm

Location:
First Christian Church of Orange
1130 E Walnut
Orange, CA
(Between Tustin & Cambridge)

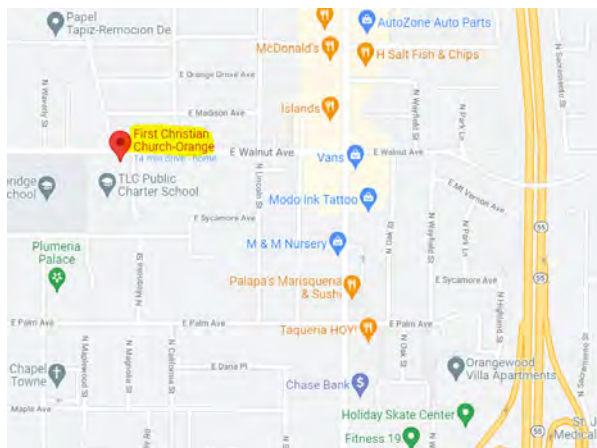

We are on the Web!
www.ocmafc.org



Return Address:
OCMAFC
P.O. Box 10595
Santa Ana, CA 92711

To:

[Empty rounded rectangular box for recipient address]

First Class Mail